

Electrocyclic Reactions. II. The Competition of Steric and Electronic Effects and the Stereochemistry of Nonpolar $2 + 2$ Cycloadditions

Nicolaos D. Epiotis

Contribution from the Department of Chemistry, Princeton University, Princeton, New Jersey 08540. Received May 7, 1971

Abstract: The determination of the stereochemistry of $2 + 2$ nonpolar cycloadditions by steric and electronic effects is examined. It is shown that a consideration of both the electronic and orbital overlap factors involved leads to a qualitative prediction of the stereoselectivity of nonpolar $2 + 2$ cycloadditions, if one views the cycloaddition as a concerted one. These results are contrasted with the current belief about the intermediacy of biradicals in such reactions.

We have seen previously how the $2 + 2$ cycloaddition exhibits a spectral behavior in terms of its stereochemical course ranging from predominantly $s + a$ union of cycloaddends in the case of a nonpolar, or AD-like, cycloaddition, to predominantly $s + s$ union of cycloaddends in the case of a polar, or AX-like, cycloaddition.¹ We have further shown that whenever an antarafacial cycloaddition takes place, there are two possible $s + a$ transition states which are differentially stabilized through the interaction of the two partners. We have seen that the $s + a$ transition state which allows the acceptor partner to sustain bond rotation during the cycloaddition is electronically more favorable than the alternative antarafacial transition state which allows the donor partner to sustain bond rotation during the cycloaddition. The electronically favorable and unfavorable transition states for the $s + a$ union of two cycloaddends are shown in Figure 1. The above considerations refer to electronic stabilization of transition states; hence, in order to complete the picture one should also assess the difference in energy of the two transition states due to orbital overlap effects. We have seen that such effects are extremely important because the magnitude of the stabilization energy upon $s + a$ or $s + s$ union of two cycloaddends depends upon the square of the resonance integral of the two uniting p orbitals at each union site, and the resonance integral depends upon the degree of orbital overlap of the two uniting p orbitals at each union site. The degree of overlap at the transition state is dictated by the degree and pattern of substitution of the two cycloaddends and in Figure 1 one can see that in both transition states the important nonbonded repulsive interactions are H-H interactions, while in both cases the bulky substituent, R_1 or R_2 , points away from the nearby H atom. Such an absence of orbital overlap effects is not to be expected when cycloadditions of multisubstituted ethylenes are attempted. In those cases orbital overlap effects will determine the stereochemistry of the reaction jointly with the electronic effects we have previously discussed.

(1) N. D. Epiotis, *J. Amer. Chem. Soc.*, **94**, 1924 (1972). According to our perturbation treatment of cycloaddition reactions, the interaction of two cycloaddends gives rise to a stabilization energy the magnitude of which depends on the phase compatibility of the interacting MO's, their energy separation, and their overlap. The first two factors are termed electronic factors and the third factor orbital overlap factor.

Nonpolar Cycloaddition of Geometrically Isomeric Olefins

The Competition of Steric and Electronic Effects.

An excellent opportunity for the understanding of the relative importance of steric and electronic effects in the case of an AD-like $2 + 2$ cycloaddition proceeding by $s + a$ union of cycloaddends is provided by the reactions of geometrical isomers of an olefin with a common olefinic substrate. Thus, while the electronic factors involved in the cycloaddition reaction remain roughly constant, the orbital overlap factors will vary according to the geometry of the isomeric cycloaddend participating in the reaction. Hence, we shall consider the cycloaddition of a tetrasubstituted ethylene, a trisubstituted ethylene, and a disubstituted ethylene, with the geometric isomers of a disubstituted ethylene. The two partners are assumed to bear like substituents so that a typical case of a nonpolar, AD-like, cycloaddition will result.

(A) **Reaction of a Tetrasubstituted Ethylene with a Disubstituted Ethylene.** We first consider the reaction of a tetrasubstituted ethylene with a disubstituted ethylene and assume that the former acts as a donor and the latter as the acceptor.² Since the reaction is nonpolar in nature because of the nature of substitution of the two ethylenes, the cycloaddition should prefer reaction *via* $s + a$ union of cycloaddends. Since two $s + a$ modes of union are possible, we shall consider the effect of geometrical isomerism upon the mode of $s + a$ union.

We first examine the reaction of the tetrasubstituted ethylene with the *cis* disubstituted ethylene. The two possible $s + a$ transition states are shown in Figure 2a. It can be seen that of the two possible transition-state configurations, Ia is favored electronically, since it involves bond rotation within the acceptor molecule; it is also favored in terms of orbital overlap effects, since it involves the minimum of nonbonded repulsions between substituents in proximity, over IIa. Hence, the major product will involve rotation in the *cis*-disubstituted ethylene and the minor product will involve rotation in the tetrasubstituted ethylene.

The two possible $s + a$ transition states for the reaction of the tetrasubstituted ethylene with the *trans* disubstituted ethylene are shown in Figure 2b. It can

(2) An example would be the cycloaddition of tetramethoxyethylene to 1,2-dimethoxyethylene.

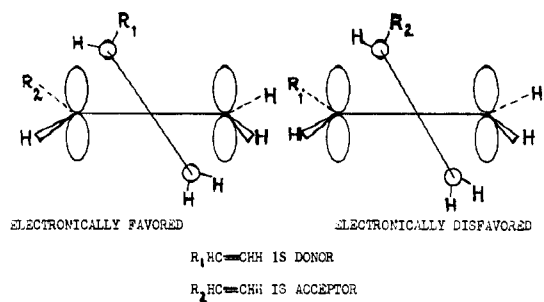

Figure 1. The electronically preferred transition state for the case of a nonpolar cycloaddition. The electronically favored transition state involves bond rotation within the acceptor moiety.

be seen that of the two possible transition-state configurations, Ib is electronically favored over IIb, while IIb is favored over Ib in terms of orbital overlap effects. Thus, product distribution will be determined by the relative importance of electronic and orbital overlap effects. We shall assume that in an AD cycloaddition orbital overlap effects are more important than electronic effects and justify this assumption later. Hence, the major product of the reaction will involve rotation in the tetrasubstituted ethylene moiety and the minor product will involve rotation in the trans-disubstituted ethylene moiety.

In the event that no assumption is made regarding the relative importance of electronic and orbital overlap effects, one should still expect that more cycloadducts of retained stereochemistry with respect to the disubstituted ethylene moiety will be found in the case of the tetrasubstituted ethylene-trans disubstituted ethylene reaction rather than in the case of the tetrasubstituted ethylene-cis disubstituted ethylene reaction. When the tetrasubstituted ethylene assumes the role of the acceptor and the disubstituted ethylene the role of the donor, orbital overlap considerations remain unaltered, but electronic considerations are reversed. Specifically, the reaction of a tetrasubstituted ethylene with a cis disubstituted ethylene will give rise to two possible $s + a$ transition states, the relative energy of which will depend upon the relative importance of orbital overlap and electronic effects. Under the assumption that orbital overlap effects are more important than electronic effects in an AD cycloaddition, the major product of the reaction will involve rotation in the cis disubstituted ethylene moiety and the minor product will involve rotation in the tetrasubstituted ethylene moiety. On the other hand, the reaction of the tetrasubstituted ethylene with the trans disubstituted ethylene will give rise to two possible $s + a$ transition states, one of which is favored over the other in terms of both electronic and orbital overlap effects. The major product of this reaction will involve rotation in the tetrasubstituted ethylene moiety and the minor product will involve rotation in the trans disubstituted ethylene moiety. In the event that no assumption is made regarding the relative importance of orbital overlap and electronic effects, one should still expect that more cycloadducts of retained stereochemistry with respect to the disubstituted ethylene moiety will be found in the case of the tetrasubstituted ethylene-trans disubstituted ethylene reaction rather than in the case of the tetrasubstituted

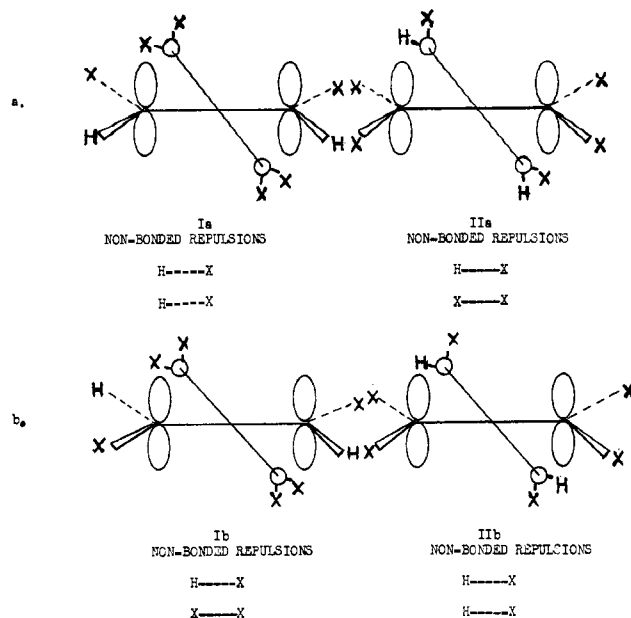

Figure 2. Electronic and orbital overlap differences of the two possible $s + a$ transition states for the case of (a) cis disubstituted ethylene-tetrasubstituted ethylene and (b) trans disubstituted ethylene-tetrasubstituted ethylene reactions.

ethylene-cis disubstituted ethylene reaction. One very important conclusion can be drawn at this point. The degree of loss of stereochemistry of an olefin during a nonpolar AD cycloaddition will depend on its geometrical configuration and will in general be higher for the cis isomer rather than the trans isomer. Additional examples will show that this is a general conclusion.

(B) Reaction of a Trisubstituted Ethylene with a Disubstituted Ethylene. The same discussion as in the previous case is valid for the case of the reaction of a trisubstituted ethylene with disubstituted cis and trans ethylenes. The two possible transition states for the $s + a$ union of the cycloaddends for the reaction of a trisubstituted ethylene with cis and trans disubstituted ethylene are shown in Figure 3. If one assumes that the trisubstituted ethylene acts as the donor and the disubstituted ethylene as the acceptor, it becomes clear that transition-state Ia is favored over transition-state IIa in terms of both electronic and orbital overlap effects. On the other hand, transition-state Ib is favored electronically over transition-state IIb, but the latter is favored over the former in terms of orbital overlap effects. The dominance of orbital overlap effects over electronic effects will make transition-state IIb the preferred transition state of the reaction. Reversal of the roles of donor and acceptor reverses electronic effects but leaves orbital overlap effects the same. In such a case, transition-state Ia will be favored in terms of orbital overlap effects over transition-state IIa, but the latter will be favored electronically over the former. Hence, transition-state Ia will be the preferred transition state of the reaction. On the other hand, transition-state IIb will be favored in terms of both electronic and orbital overlap effects over transition-state Ib, and, accordingly, will be the preferred transition state of the reaction.

(C) Reaction of a Disubstituted Ethylene with a Disubstituted Ethylene. Proceeding as before, we now

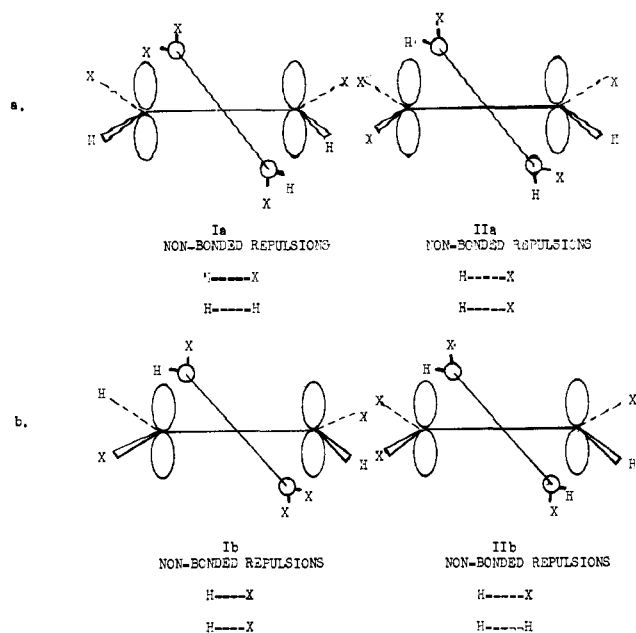

Figure 3. Electronic and orbital overlap differences of the two possible $s + a$ transition states for the cases of (a) disubstituted ethylene-trisubstituted ethylene and (b) trans disubstituted ethylene-trisubstituted ethylene reactions.

consider the reaction of a cis and of a trans disubstituted ethylene with a disubstituted ethylene. Furthermore, the substituents of the two olefins are similar in electronic properties but nonidentical so that a donor-acceptor distinction can be made. The two possible $s + a$ transition states for each of the reactions cis-cis and cis-trans are shown in Figure 4, while the two possible $s + a$ transition states for each of the reactions trans-cis and trans-trans are shown in Figure 5. It can be seen that, assuming $XHC=CHX$ acts as the donor and $YHC=CHY$ as the acceptor, transition-state Ia of Figure 4 is electronically favored over transition-state IIa, assuming that orbital overlap effects are nearly equal,³ while transition-state Ib is disfavored in terms of orbital overlap effects relative to transition-state IIb, but is also electronically favored over it. Transition-states Ia and IIb will then be the preferred transition states for the two reactions. A reversal of the roles of donor and acceptor leads to the conclusion that transition-state IIa will be electronically favored over transition-state Ia, assuming that orbital overlap effects are nearly equal, while transition-state IIb will be favored in terms of both electronic and orbital overlap effects over transition-state Ib. Transition-states IIa and IIb will then be the preferred transition states for the two reactions.

Under the same assumptions, it can be moreover seen that transition-state Ia of Figure 5 is favored in terms of both electronic and orbital overlap effects over transition-state IIa, while transition-state Ib is electronically favored over transition-state IIb. Hence, transition-states Ia and Ib will be the preferred transition states for the two reactions. A reversal of donor-acceptor roles leads to the conclusion that transition-state Ia will be favored in terms of orbital overlap effects and disfavored electronically relative to transition-state IIa, while transition-state IIb will be

(3) The bulk of substituents X and Y is assumed to be nearly equal.

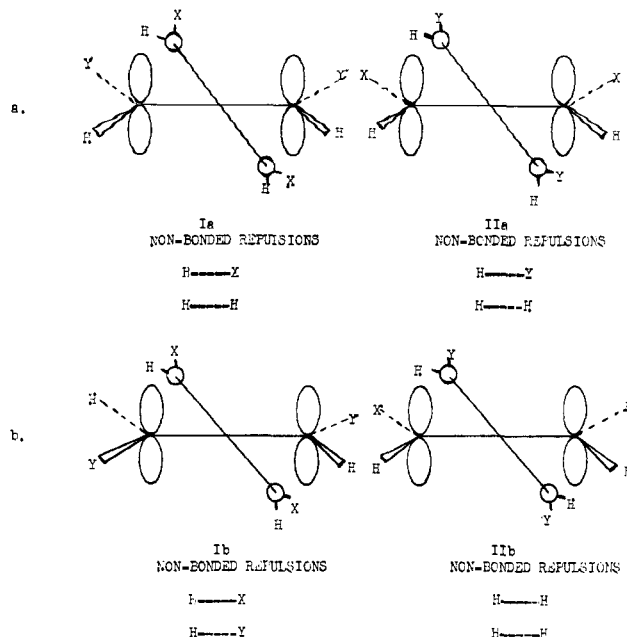

Figure 4. Electronic and orbital overlap differences of the two possible $s + a$ transition states for the cases of the reaction of (a) cis disubstituted ethylene and cis disubstituted ethylene and (b) cis disubstituted ethylene and trans disubstituted ethylene.

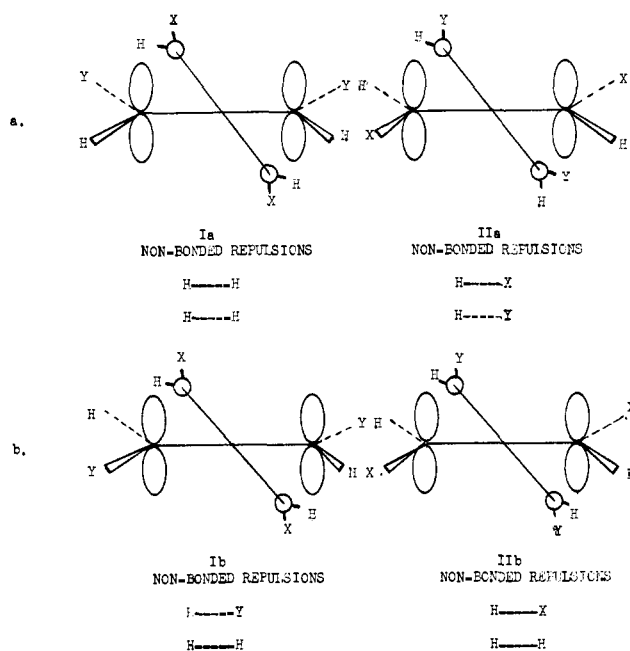

Figure 5. Electronic and orbital overlap differences of the two possible $s + a$ transition states for the cases of the reaction of (a) trans disubstituted ethylene and cis disubstituted ethylene and (b) trans disubstituted ethylene and trans disubstituted ethylene.

favored electronically over transition-state Ib. According to our assumptions, transition-states Ia and IIb will be the preferred transition states for the two reactions. We summarize our conclusions in Table I.

An examination of Table I indicates that stereochemical loss of configuration is more extensive when a cis rather than a trans olefin takes part in a non-polar AD cycloaddition. This finding parallels the predictions of the "freely rotating biradical" mechanism, according to which a biradical intermediate

Table I. The Relative Retention of Configuration of Isomeric Olefins Partaking in a Nonpolar 2 + 2 Cycloaddition

Reactants		Stereochemistry of major ^a product with respect to confign of II		Rel retention of confign in products between isomers
I	II	I = D, II = A	I = A, II = D	
XXC=CXX	Trans XHC=CHX	Retention	Retention	Trans > Cis
XXC=CXX	Cis XHC=CHX	Rotation	Rotation	
XHC=CXX	Trans XHC=CHX	Retention	Retention	Trans > Cis
XHC=CXX	Cis XHC=CHX	Rotation	Rotation	
XHC=CHX (trans)	Trans YHC=CHY	Rotation	Retention	Trans > Cis
XHC=CHX (trans)	Cis YHC=CHY	Rotation	Rotation	
XHC=CHX (cis)	Trans YHC=CHY	Retention	Retention	Trans > Cis
XHC=CHX (cis)	Cis YHC=CHY	Rotation	Retention	

^a D = donor, A = acceptor.

gives rise to the thermodynamically more stable cycloadduct which usually involves a trans arrangement of the relevant substituents of the isomeric olefins.⁴ We have seen that when a nonpolar AD cycloaddition takes place, then both loss and retention of stereochemistry around the reacting double bonds are expected

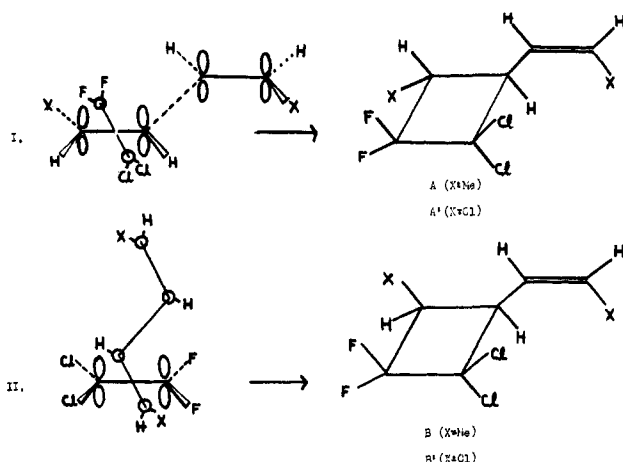

Figure 6. The two possible $s + a$ transition states and corresponding products for the reaction of "1122" and *cis,cis*-2.

since two distinct $s + a$ transition states are accessible. If one assumes that orbital overlap effects are more important than electronic effects in the case of AD cycloadditions one can always predict the stereochemistry of the major and minor products of such a reaction. The assumption that orbital overlap effects are more important than electronic effects is justified both theoretically and experimentally on the following counts. (a) Importantly, orbital overlap effects are geometric effects, namely their magnitude is raised to the second power and is thus magnified according to the simple perturbational treatment of cycloaddition reaction which yields the equation for the stabilization energy upon cycloaddend interaction, which in turn provides the basis for the examination of cycloaddition reactions. (b) When an AD cycloaddition obtains, the quantities $(E_{\text{HOMO donor}} - E_{\text{LUMO acceptor}})$ and $(E_{\text{HOMO acceptor}} - E_{\text{LUMO donor}})$ do not differ ap-

(4) There are many variants of the biradical mechanism ranging from the "freely rotating biradical" to the "restrictedly rotating biradical" mechanism. Any set of stereochemical data can be rationalized by appropriately specifying the ratio of the rate constants for ring closure and rotation around a C-C bond. On the other hand, the biradical mechanism makes straightforward predictions on orientation and other aspects of the nonpolar cycloaddition reactions.

preciably. Thus, the degree of loosening of the double bond of each partner through its interaction with the other partner is comparable; hence, the electronic stabilization of the two antarafacial transition states is comparable also. (c) The relative rates of ketene cycloadditions with substituted ethylenes are determined by both electronic and orbital overlap effects. However, when the two effects conflict, steric effects appear to dominate.⁵ Ketenes partake in nonpolar cycloadditions as a general rule.

The stereochemical course of a nonpolar AD 2 + 2 cycloaddition, as manifested in many experimental results presently rationalized in terms of biradical mechanisms, finds a full explanation in terms of a concerted mechanism of cycloaddition reactions. The classic work of Bartlett and coworkers can then be examined in this light.⁶ The cycloaddition of 1,1-difluoro-2,2-dichloroethylene (abbreviated "1122") to 1,4-dichlorobutadiene and to 2,4-hexadiene exemplifies our theory and allows predictions to be made without any recourse to biradical intermediates. The reaction of 1 and 2 may be an AM-like cycloaddition, assuming that a

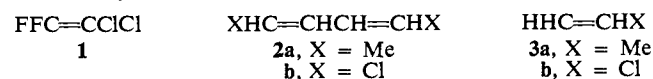

planar diene participates in the reaction, or it may be an AD-like cycloaddition, assuming that the two ethylenic frameworks of the substituted butadiene are oriented perpendicular to each other. The latter case, in effect, is a cycloaddition of 1 and 3. Since the reaction of 1 and 2 will be intermediate between an AD- and AM-type cycloaddition, one should expect the cycloaddition to take place preferentially in an antarafacial fashion.

We shall first consider the reaction of *cis,cis*-2 with 1. The two possible $s + a$ transition states are shown in Figure 6. Transition-state I will be favored in terms of both electronic and orbital overlap effects over transition-state II if 1 acts as the donor and 2 as the acceptor while it will be favored on orbital overlap grounds and disfavored on electronic grounds relative to transition-state II if 1 acts as an acceptor and 2 as a donor. In either case, the preferred transition state will be I and the major product of the reaction will be A.

We then consider the reaction of *trans,trans*-2 with 1. The two possible $s + a$ transition states are shown in Figure 7. Following the same reasoning as before,

(5) T. Dominh and O. P. Strausz, *J. Amer. Chem. Soc.*, **92**, 1766 (1970).

(6) L. K. Montgomery, K. Schueller, and P. D. Bartlett, *ibid.*, **86**, 622 (1964); P. D. Bartlett and G. E. H. Wallbillich, *ibid.*, **91**, 409 (1969).

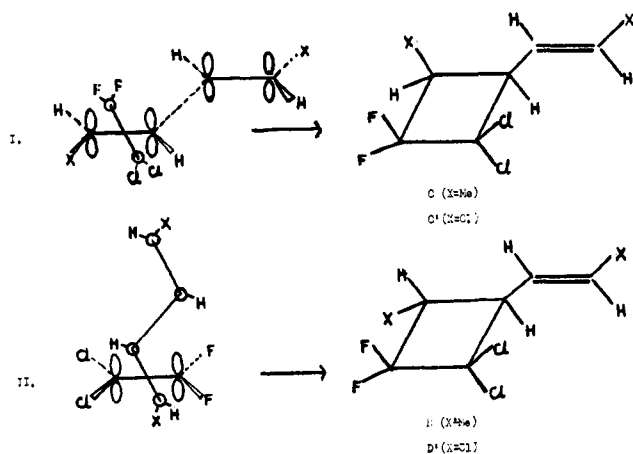

Figure 7. The two possible $s + a$ transition states and corresponding products for the reaction of "1122" and *trans,trans*-2.

we can see that transition-state II is favored over transition-state I irrespective of donor-acceptor relationships. Hence, the major product of the reaction will be D.

We then consider the reaction of *cis,trans*-2 and 1. The four possible $s + a$ transition states are shown in Figure 8. Following the same reasoning as before, we can see that the two most favorable transition states will be I and II; hence the major products of the reaction will be A and D and the minor ones B and C. Table II summarizes our predictions and compares

Table II. Predicted and Observed Loss of Stereochemistry of Isomeric Dienes Partaking in a Nonpolar 2 + 2 Cycloaddition

Reactants	Predicted products		Experimental result
	Major	Minor	
"1122" + 2a <i>cis-cis</i>	A	B	75.9% A, 24.1% B ^a
"1122" + 2a <i>trans-trans</i>	D	C	84.2% D, 15.8% C
"1122" + 2a <i>cis-trans</i>	A + D	B + C	44.2% D, 34.2% A, 13.7% C, 7.9% B
"1122" + 2b <i>cis-cis</i>	A	B	53.6% A, 33.5% B ^b
"1122" + 2b <i>trans-trans</i>	D	C	65.5% D, 23.1% C
"1122" + 2b <i>cis-trans</i>	A + D	B + C	40.7% A, 30.5% D, 16.7% B, 10.7% C

^a Yields based on total cycloadduct obtained. ^b Yields based on total reacted diene.

them to experimental results of Bartlett, *et al.*

The agreement of theory and experiment demonstrated in Table I provides additional support to our claim that the majority of cycloaddition reactions proceeds with simultaneous orbital overlap at both union sites, or, in other words, are concerted. We would like now to show how our theory is capable of making even more refined predictions about reactivity.

We have seen that the reactions of *cis,cis* and *trans,trans* 1,4-disubstituted dienes with "1122" are stereoselective to different extents. The relative stereoselectivities of the two reactions can be predicted by our theory. If one assumes that in those reactions the diene acts as the donor and the olefin as the acceptor,⁷

(7) This assumption is supported by a calculation of the energies of HOMO and LUMO of each cycloaddend from ionization potential and uv data which indicates that ($E_{\text{HOMO diene}} - E_{\text{LUMO olefin}}$) is smaller than ($E_{\text{HOMO olefin}} - E_{\text{LUMO diene}}$); hence, according to our criterion for donor-acceptor assignment, the diene is the donor and the olefin the acceptor.

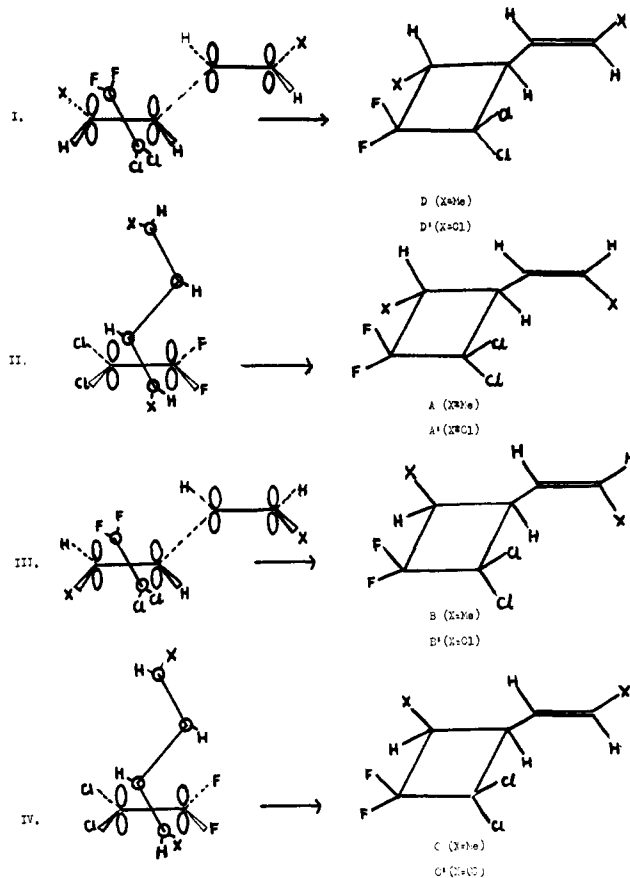

Figure 8. The four possible $s + a$ transition states and corresponding products for the reaction of "1122" and *cis,trans*-2.

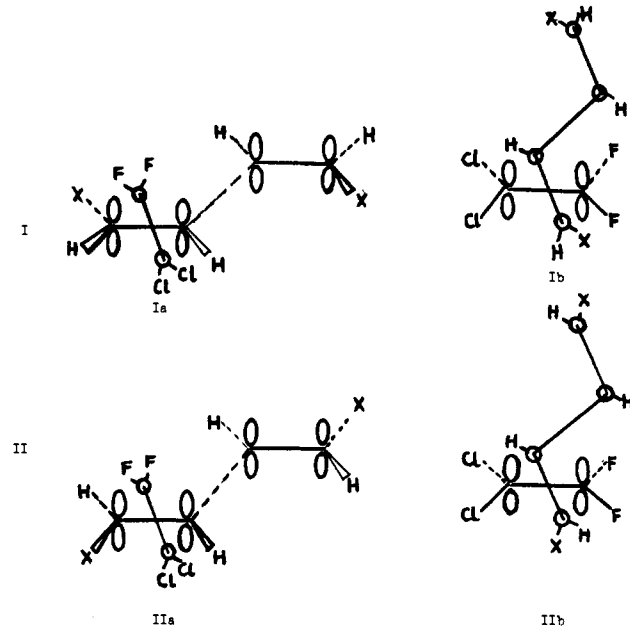

Figure 9. The two possible $s + a$ transition states for the reaction of "1122" with *cis,cis*-2 and *trans,trans*-2. In the first case, transition-state Ia is sterically favored over transition-state Ib, while transition-state Ib is electronically favored over transition-state Ia. In the second case, transition-state IIb is favored both sterically and electronically over transition-state IIa.

then the relative stabilization of the two transition states leading to major and minor products can be assessed. This is done in Figure 9. Since in both reactions the relative steric interactions in the two

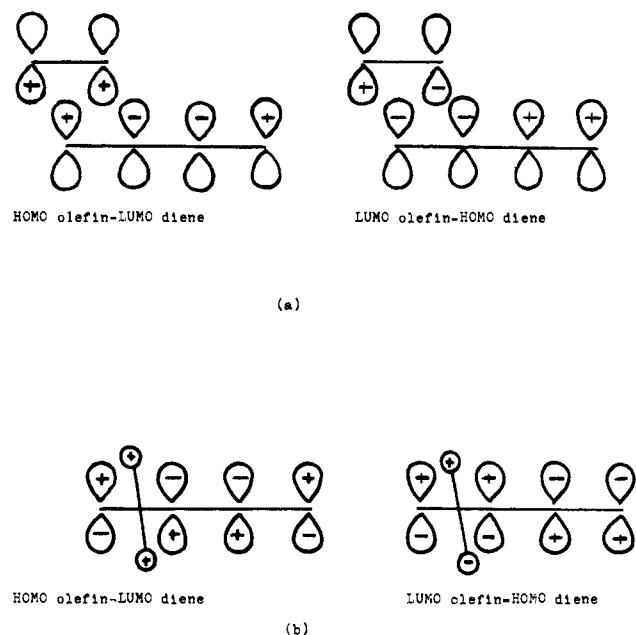
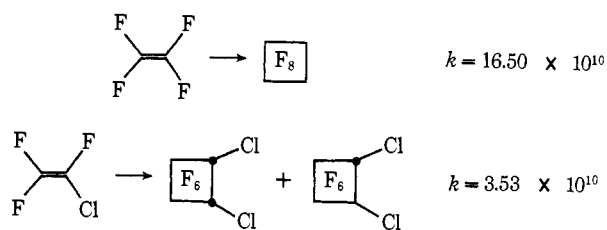

Figure 10. Intermolecular interactions leading to double bond isomerization. Case a involves isomerization of the free diene double bond without concurrent cycloaddition. Case b involves isomerization of the free diene double bond without concurrent cycloaddition.

transition states are identical, one can predict the relative stereoselectivity of the reactions. In one case, the reaction of the trans,trans diene, the preferred transition state is favored in terms of both electronic and orbital overlap effects, while in the other case, the reaction of the cis,cis diene, the preferred transition state is favored in terms of orbital overlap effects but disfavored in terms of electronic effects. Hence, the reaction of the trans,trans diene with "1122" is more stereoselective than the corresponding reaction of the cis,cis diene (Table II).

Nonstereochemical Criteria of the Biradical Mechanism. Previously, we focused attention on the stereoselectivity of nonpolar 2 + 2 cycloadditions. We now consider other aspects of the reaction where clear-cut predictions can be made on the basis of our theory and compare them with the corresponding predictions of the biradical mechanism.

The rates of nonpolar cycloadditions will be predominantly influenced by orbital overlap effects as discussed in the previous section. This implies that as the bulk of substituents around a double bond increases the rate of the s + a cycloaddition will decline. The following results demonstrate that our expectations indeed materialize.⁸ These results are evidence against



the biradical mechanism. Since chlorine substituents are better than fluorine substituents in stabilizing

(8) J. R. Lacher, G. W. Tompkin, and J. D. Park, *J. Amer. Chem. Soc.*, **74**, 1693 (1952).

radicals,⁹ it would have been expected that the dimerization of tetrafluoroethylene would have been slower than the dimerization of chlorotrifluoroethylene because the biradical formed in the former case is less stable than the biradical formed in the latter case.

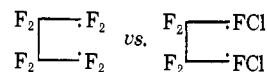

More data pertaining to cases which allow such a clear distinction of mechanisms are needed.

Another important aspect of nonpolar 2 + 2 cycloadditions of a diene and an olefin is diene isomerization. The results of Bartlett, *et al.*, show that:⁸ (a) the diene isomerizes during the reaction; (b) the free double bond of the diene can also lose its initial stereochemistry in the final cycloadduct, although to a minor extent. The transition states for the two processes are shown in Figure 9. In each case there are two stabilizing interactions, namely, an interaction between the HOMO of the diene and the LUMO of the olefin, and *vice versa*. The HOMO-LUMO interactions in each of the transition states give rise to charge transfer from the HOMO of one cycloaddend to the LUMO of the other cycloaddend and thus, charge transfer results in all cases in the weakening of the π bonds of both the olefin and the diene. Under these circumstances isomerization can result. Hoffmann and Günther have utilized the same perturbational principles in discussing the effects of substituents on the valence isomerization of organic molecules.¹⁰ Diene isomerization during cycloaddition has been traditionally taken as strong support for the biradical mechanism.

We have seen above that diene isomerization is indeed compatible with a molecular interaction of cycloaddends. Furthermore, the predominant retention of stereochemistry in the bond of the diene which does not participate in the cycloaddition has been attributed by the biradical mechanism to the configuration stability of the allyl radical. The experimental evidence which can be found in the literature¹¹ demonstrates that the configurational stability of allyl radicals can be high or low depending on: (a) the nature of the reaction which produces the allyl radical; (b) the conditions of the reaction; (c) the substituents on the radical. Under these circumstances any predictions of the biradical mechanism with respect to this particular aspect of the cycloaddition are rendered dubious. We have seen that the stereochemical integrity of the free diene bond can be destroyed concurrently with cycloaddition due to the nature of the MO interactions of the cycloaddends at the transition state. The transition state of such a process will be higher in energy relative to the transition state of a cycloaddition proceeding with retention of stereochemistry at the free diene π bond; in the former case energy has to be provided to initiate s + a bonding of the cycloaddends plus rotation of the free diene bond while in the latter case energy has to be provided only

(9) P. D. Bartlett, L. K. Montgomery, and B. Seidel, *ibid.*, **86**, 616 (1964).

(10) R. Hoffman, *Tetrahedron Lett.*, 2907 (1970); H. Günther, *ibid.*, 5173 (1970).

(11) C. Walling and W. Thaler, *J. Amer. Chem. Soc.*, **83**, 3877 (1961); W. A. Thaler, A. A. Oswald, and B. E. Hudson, *ibid.*, **87**, 311 (1965); D. B. Denney, R. M. Hoyte, and P. T. MacGregor, *Chem. Commun.*, 1241 (1967); R. T. Crawford, J. Hamelin, and B. Strehlke, *J. Amer. Chem. Soc.*, **93**, 3810 (1971).

to initiate $s + a$ bonding of the cycloaddends. Thus, according to our theory only minor loss of the stereochemistry of the free double bond of the diene cycloadduct is expected in good accord with the results of Bartlett, *et al.*⁶

Finally, we have to account for the orientational selectivity of the nonpolar $2 + 2$ cycloadditions. In this case the biradical mechanism makes straightforward predictions. The orientational selectivity of a nonpolar $2 + 2$ cycloaddition is correctly predicted to be controlled by the formation of the most stable biradical intermediate. However, one has to be reminded that the biradical mechanism also makes correct predictions for the orientational selectivity of

$4 + 2$ cycloadditions.¹² In other words, the biradical mechanism accounts for the orientational selectivity of both a presumed two-step and one-step cycloaddition! This certainly makes the reliability of the orientational criteria appear dubious.

Acknowledgments. This work was generously supported by Princeton University Fellowships (1967–1969), a Monsanto Fellowship (1969–1970), and National Institute of Health Grant No. AI-07766. The author wishes to thank Professors P. D. Bartlett, J. A. Berson, and R. Hoffmann for their helpful comments and Professor P. von R. Schleyer for stimulating discussions and his interest in this work.

(12) Y. A. Titov, *Russ. Chem. Rev.*, **31**, 267 (1962).

Electrocyclic Reactions. III. The Importance of Donor–Acceptor Interactions in Photocycloaddition Reactions

Nicolaos D. Epitotis

Contribution from the Department of Chemistry, Princeton University, Princeton, New Jersey 08540. Received May 7, 1971

Abstract: The recognition of the donor–acceptor relationship of the cycloaddends leads to the description of the entire spectrum of photochemical cycloadditions. Interaction diagrams are utilized in order to develop our predictions. The Woodward–Hoffmann rules are shown to hold for only parts of the entire photocycloaddition spectrum. The suggestion is made, as in the case of thermal cycloadditions, that most photocycloadditions are concerted and not stepwise as it had been thought before.

The stereochemistry of photocycloaddition reactions has remained for a long time one of the problems in the realm of mechanistic organic chemistry in demand of satisfactory interpretation.¹ The first step toward the solution of the problem was made when Woodward and Hoffman published their formulation of thermally and photochemically allowed concerted reactions.² We have already proposed that the thermal Woodward and Hoffmann rules are strictly applicable to only a small segment of the $2 + 2$ cycloaddition spectrum and uniformly applicable to the entire $4 + 2$ cycloaddition spectrum.³ We have every reason to believe that a corresponding inadequacy of the Woodward–Hoffmann rules regarding photochemical cycloadditions will also manifest itself. We shall utilize simple perturbation theory results described before to develop some predictive ideas concerning the stereochemistry of photocycloaddition reactions.

I. Theoretical Background

We shall utilize the perturbational approach described before in order to examine photochemical cycloadditions. Accordingly, an interaction diagram is constructed depicting the MO's of the cycloaddends, the electronic configuration of each cycloaddend, and the most important MO interactions between the two cycloaddends. A consideration of energy level prox-

imity effects, or electronic effects, and of orbital overlap effects, or steric effects, then leads us to the determination of the preferred transition state of the reaction.

At this point, it is necessary to consider some important differences between a molecule in a ground state and one in an excited state.

(a) The electronic configuration of an excited molecule is different from the electronic configuration of the same molecule in its ground state. The distribution of the electrons among the MO's of the molecule is different in the excited and in the ground state.

(b) The excited molecule has generally a different geometry than the same molecule in its ground state. Olefinic molecules in their excited state exhibit a twisting of the double bond about their axis. Interaction diagrams are constructed under the assumption that both excited-state and ground-state photocycloaddends are in their ground-state geometry. Accordingly, any drastic deviation of the excited molecule geometry from the geometry of the same molecule in its ground state might create an uncertainty in the accuracy of any predictions made on the basis of such interaction diagrams. This difficulty can be easily circumvented by confining the photoexcited π system undergoing cycloaddition in a ring or any rigid framework. In this fashion the degree of twisting of any double bond about its axis can be restricted and the geometry of the ground and the excited state of the molecule can be considered not to be significantly different. It should be pointed out that in the case of ethylene a twist of the

(1) P. E. Eaton, *Accounts Chem. Res.*, **1**, 50 (1968).
 (2) R. B. Woodward and R. Hoffmann, *Angew. Chem., Int. Ed. Engl.*, **8**, 781 (1969).
 (3) N. D. Epitotis, *J. Amer. Chem. Soc.*, **94**, 1924, 1935 (1972).